

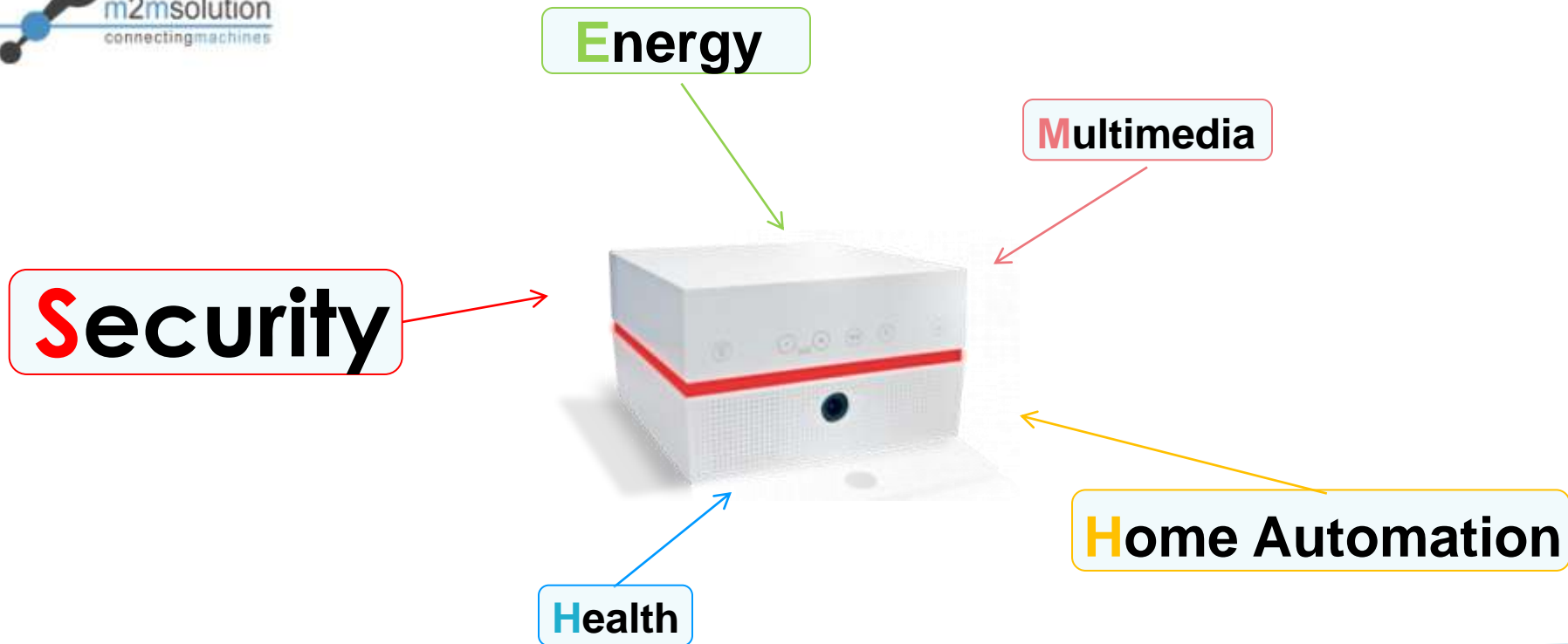

ict for sustainable homes

November 17-19, 2010 - Plaza Hotel, Nice, France



Nov. 2010

Our Vision of « Connected homes »



Click to see
the movie

The i-Domotics market

Security

Energy

Multimedia

Automatism

Health

Based on a market study from 'basic', What are the 7 primary services needed by people ?

- ▶ Auto-surveillance of the house
- ▶ Technical Auto-surveillance
- ▶ Management of the Urgencies
- ▶ Energy saving mode
- ▶ Optimisation of energy at Home
- ▶ Alert on Water consumption
- ▶ Alert on Energy consumption

65% of people wants to have a fully integrated solution :

- ▶ Security,
- ▶ Home Automation,
- ▶ Energy Management

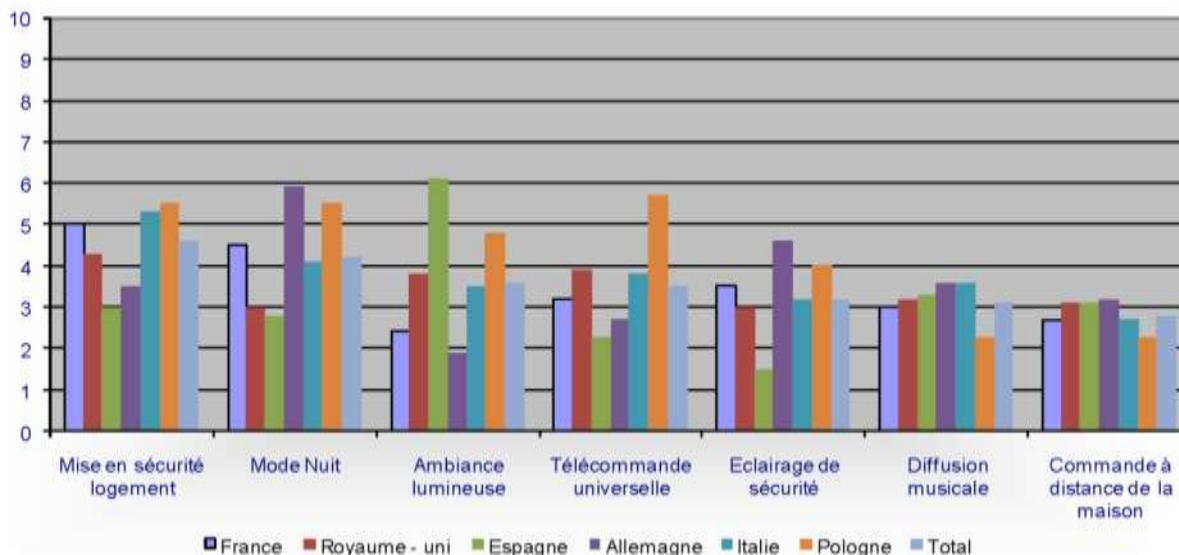

And the secondary services



Security : but not only...

M2M Solution is able to enrich its offer and to meet the future needs of services providers & consumers



Homebox specifications

- SD Card
- USB
- Ethernet
- Audio In/Out
- Vidéo Out
- Power Button
- Alimentation
- GSM
- Wifi
- Zigbee
- Bluetooth
- RF 868 MHz
- Speakers
- Camera (140)
- Microphone
- Touch Buttons



Options

- LCD or touchscreen
- DTV and more...

100% compatible and easy to fit







PC

PMP

Phone

Wap – Iphone – Midlet - IVR

Our Home Solutions Roadmap

-  Production
-  Sampling
-  In Development
-  Future

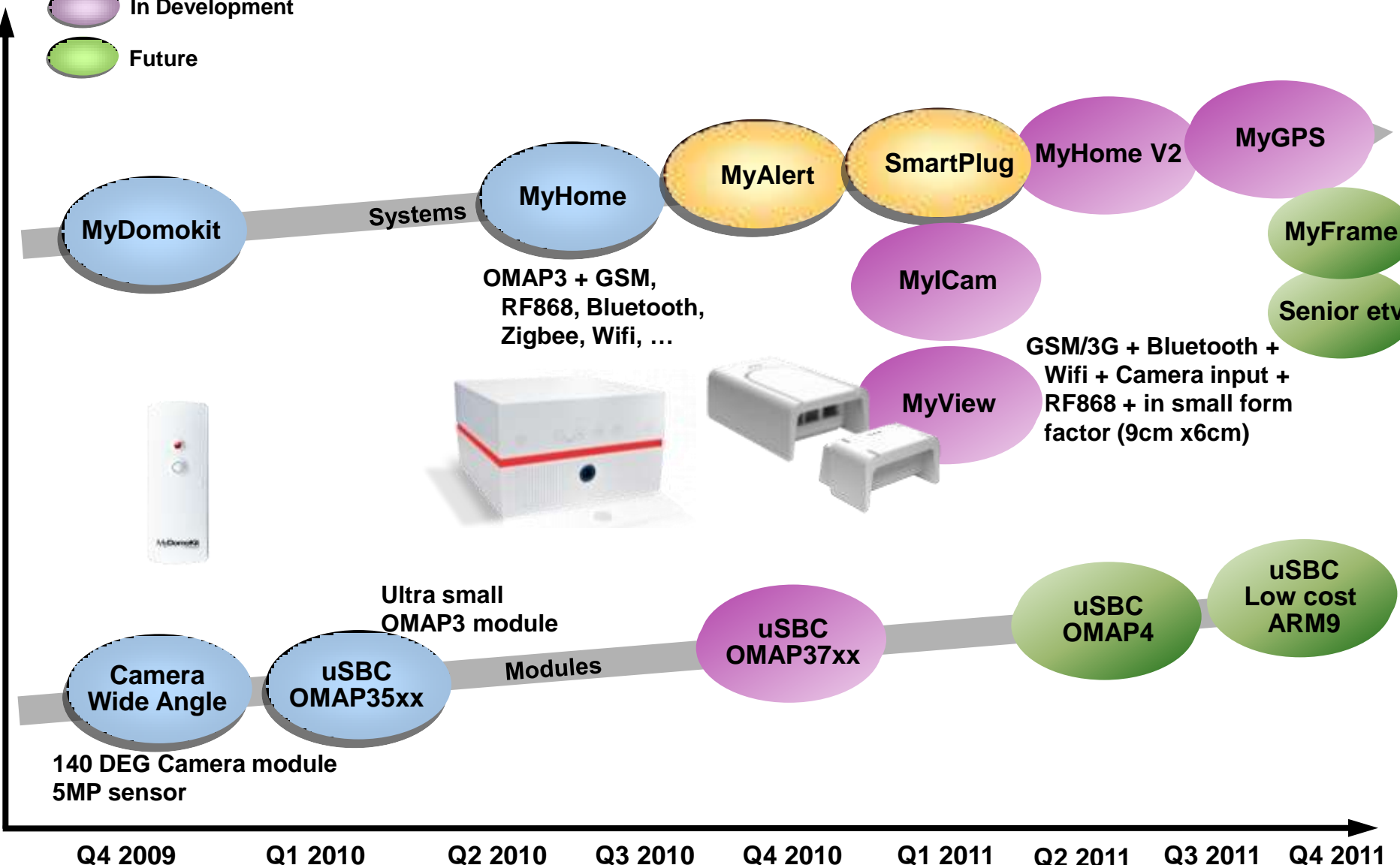

A focus on the Energy management function

Consommation de :

Electricité
 Eau
 Gaz

Toutes énergies

Du capteur :

Compteur Electrique ▼

Sur la période de :

Consommation Instantanée

1 Jour
 1 Mois
 1 An

Mercredi 30 Septembre

Consommation totale ces dernières 24h :

7.4 kWh

(Soit environ 400€/an)

Consommation cumulée :

Depuis le 01/01/2010 : 300€
 Dernier mois : 26€
 Dernier trimestre : 85€
 Dernière année : 568€

Tendances :

Par mois : (-10%)
 Par trimestre : (-2%)
 Par an : (-12%)

Value ■ Third data set 462

Unité : kWh € €/an CO₂

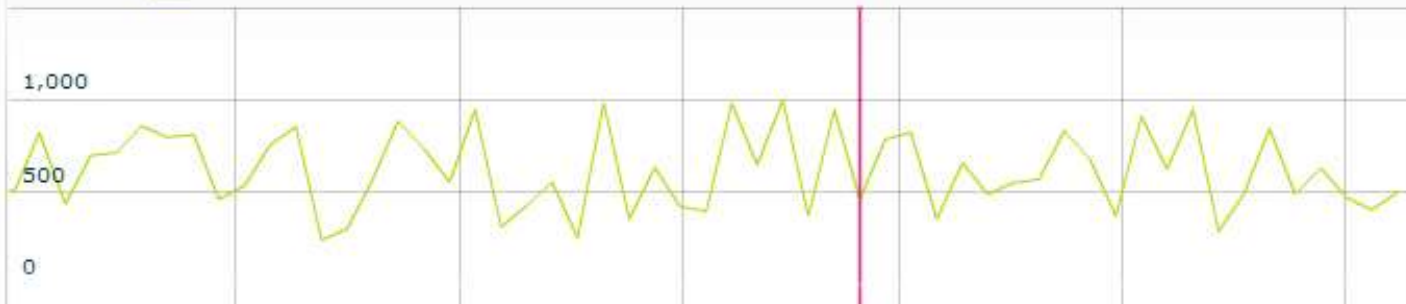

Volume ■ Third data set 3,012



Mass Market Approach

SIMPLICITY

- ▶ products and services fully « plug and use »

EVOLUTIVITY

- ▶ A complete range of additional products and services

COMMUNITY

- ▶ The idea of belonging to a community of users reinforces security.

ATTRACTIVITY

- ▶ Intuitive offers , multi-generational which meet a vital need of security

COMPETITIVITY

- ▶ Best Quality/Services/Price rate in the market

THANKS FOR YOUR ATTENTION



m2m Solution SAS

Buropolis 3 - 1240, Route des Dolines

Parc de Sophia Antipolis - 06560 Valbonne – France

Infos: +33 (0) 493 001 999 & www.m2msolution.com

Who we are ?

M2M Solution In brief

▶ **Background & Positioning**

- ▶ Founded in 2004 by Olivier Courtade (Successful pioneer in telematics and machine-to-machine since 1998) and backed by an experienced Management Team designed for key accounts monitoring
- ▶ Headquartered in Sophia Antipolis, France with an Electronics R&D center in Sofia, Bulgaria
- ▶ Development Team composed of over 24 Machine-to-Machine industry experts
- ▶ Strategic partnerships: TeleAtlas, SFR, Texas Instruments, Deltadore, BeNomad, Ogone, Netsize....
- ▶ Total control of the M2M value chain :

Electronics -> Network -> Server Platform -> End-user & Back-office Applications -> Services

▶ **Mission**

- ▶ Offer fully-blown M2M Technologies, Services and Expertise to Key Account industries willing to deploy real-time and remote services for mobile and fixed assets (Homes, Premises, Cars, Boats...)
- ▶ Build Branded and Customized offers ready to address Consumer and/or Business Markets (B-to-B-to-B and/or B-to-B-to-C)
- ▶ Reduce Time to Market necessary for deploying a low cost remote & real-time security offer (few months)

▶ **Business model**

- ▶ Minimum investment cost (software development and hardware)
- ▶ Win-win approach through a user-based monthly license fee

The Structure

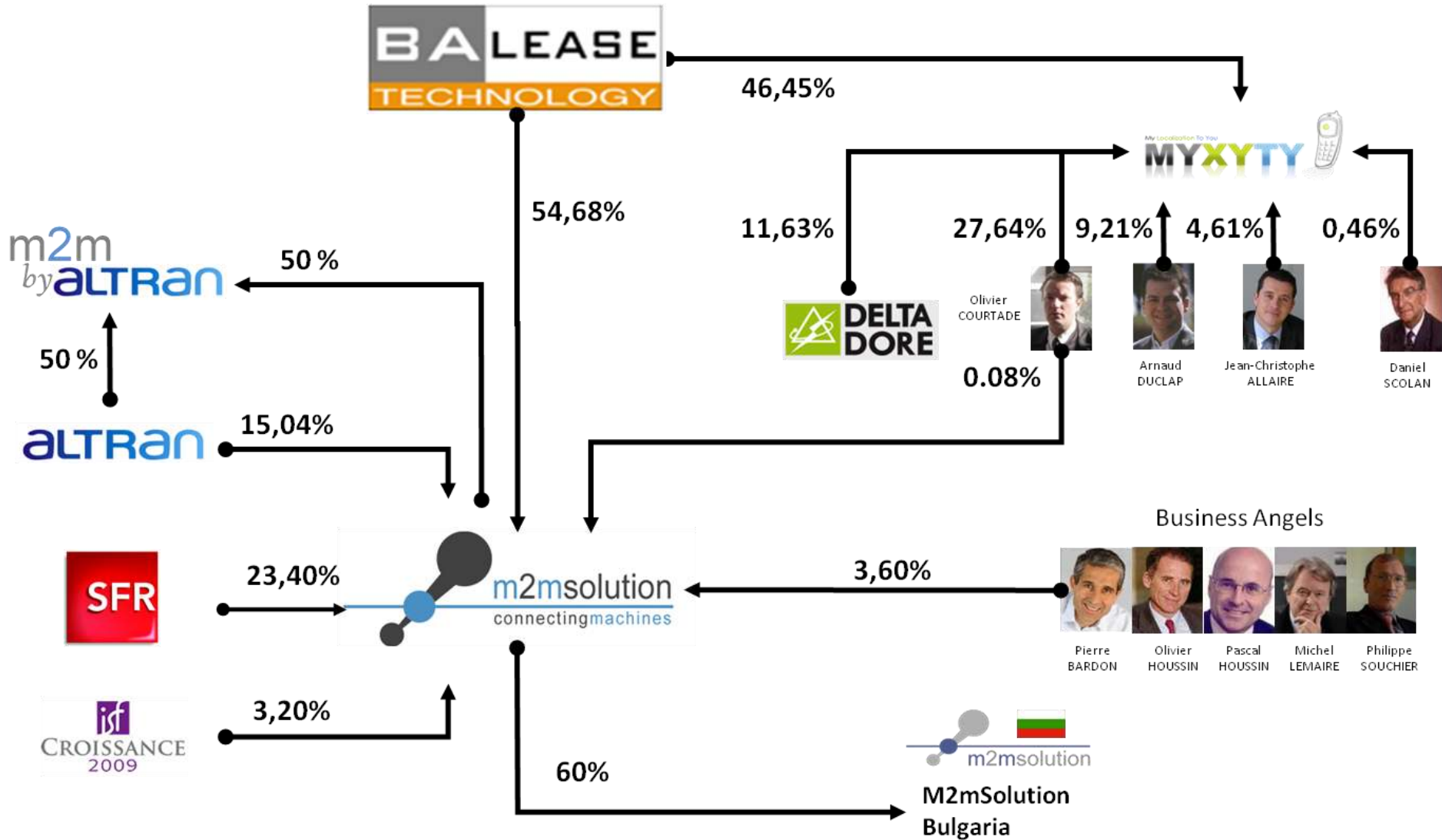

A Manager who have already achieved a success story



Olivier COURTADE, 44 years, graduated in Economic Sciences & Communication, **CEO**

- 1998 Created BALEASE: remote stolen car immobilizer
- 1999 1st GSM/GPS security module and first Internet tracking platform application
- 2001 **Sale to COBRA**, European leader in automotive security. (6,4M€)
- 2001-05 Converted **28 subsidiaries** & Int'l distributors to a **subscription** model
- 2005 Created M2M solution for developing a generic technological platform
- 2008 Created MYXYTY aimed at a mass market BtoC

Cobra, First embedded security assets for car

240 000 vehicles equipped in 28 countries (<http://www.cobraconnex.com>)

IPO December 2006: Value **168 M€**

Video France 3:



An ideal management team for key accounts monitoring

Arnaud DUCLAP, 35, Engineer Efrei + MBA HEC, **COO in M2M Solution**



8 years with Texas Instruments : EMEA Business Dev. Manager – Mass market
Responsible for the SFR deployment; Defined Roadmap

Brouk NEGOUSSE, 29, CERAM, **Director Business Services**



8 years: Balease, Nexo, Cobra - Project Marketing Manager
Expert in key accounts project management and implementation process

Olivier Philippe, 37, ENST Bretagne, **CTO**



4 years with Texas Instruments : Key Account Managing Director (Motorola, TomTom, Archos, Philips, ...)
8 years with Accenture : Solution Delivery et Consulting Telecom / IPTV

Daniel Tsvetanov, 31, Ph.D. Syst. Electronic + MBA, **Electronic Director – CEO m2m Solution Bulgaria.**



10 years background in Embedded system and Managing Project.
Telecom, Numeric cam, Remote RF, Mobile phone, IP Phone, Multimedia player

Our mission: M to M Integrator

◆ **Respond** to all the business opportunities by being reactive when faced with market demands and to provide an appropriate technological solution.

◆ **Package** complete m2m solutions for those clients (B2B) who wish to enter the complex world of Machine to Machine by providing them with the elements of the information chain.

◆ **Develop** Rapidly and easily applications and functions dedicated to the sectors of activity in question.

→ ***Time to Market***

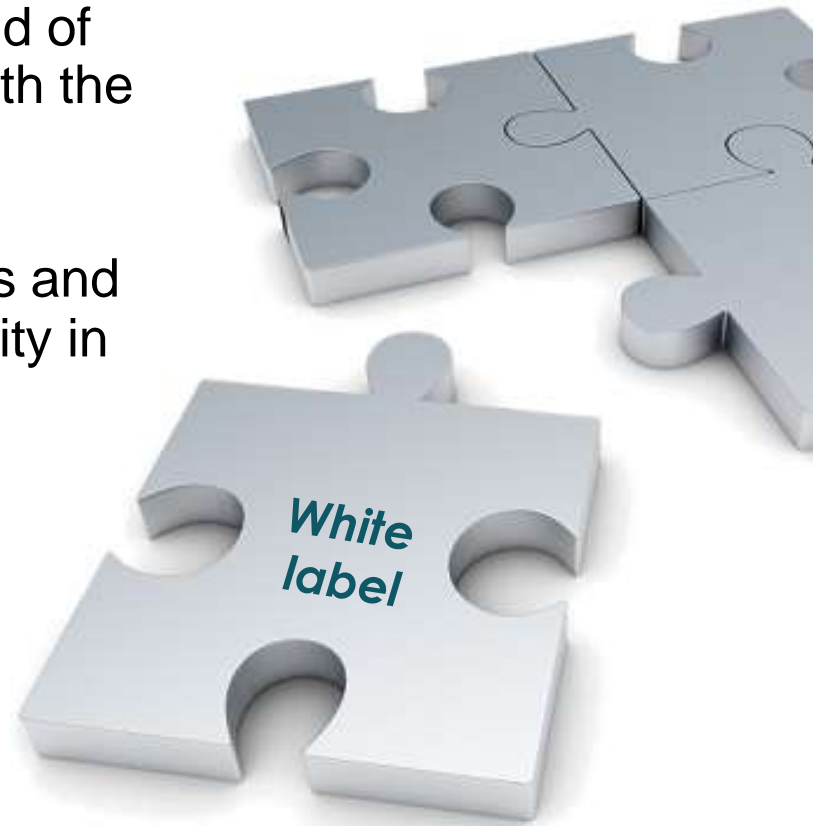

Total and unique mastery of the chain

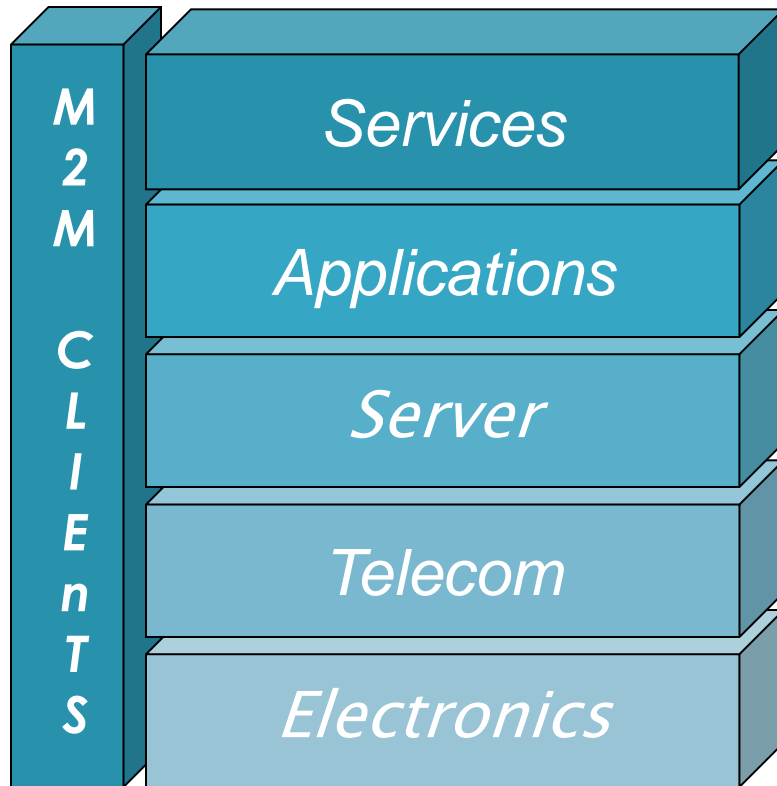

Payment – Direct debit- Auto invoicing – Interbank connection (Ogone et HSBC), Installation, ...

Development of white branded vertical software applications (Web portal, Midlet Java, Wap, Voice service, Back Office)

Multi media telematic service center, Interconnected data base with European telecom operators

Sim card provider for traffic or selection of alternate communications protocols (RFID, wifi, etc..)

Design or selection of electronic modules adapted to each sector (R&D, design, manufacture, ...)

E
N
D
U
S
E
R

Platform Architecture

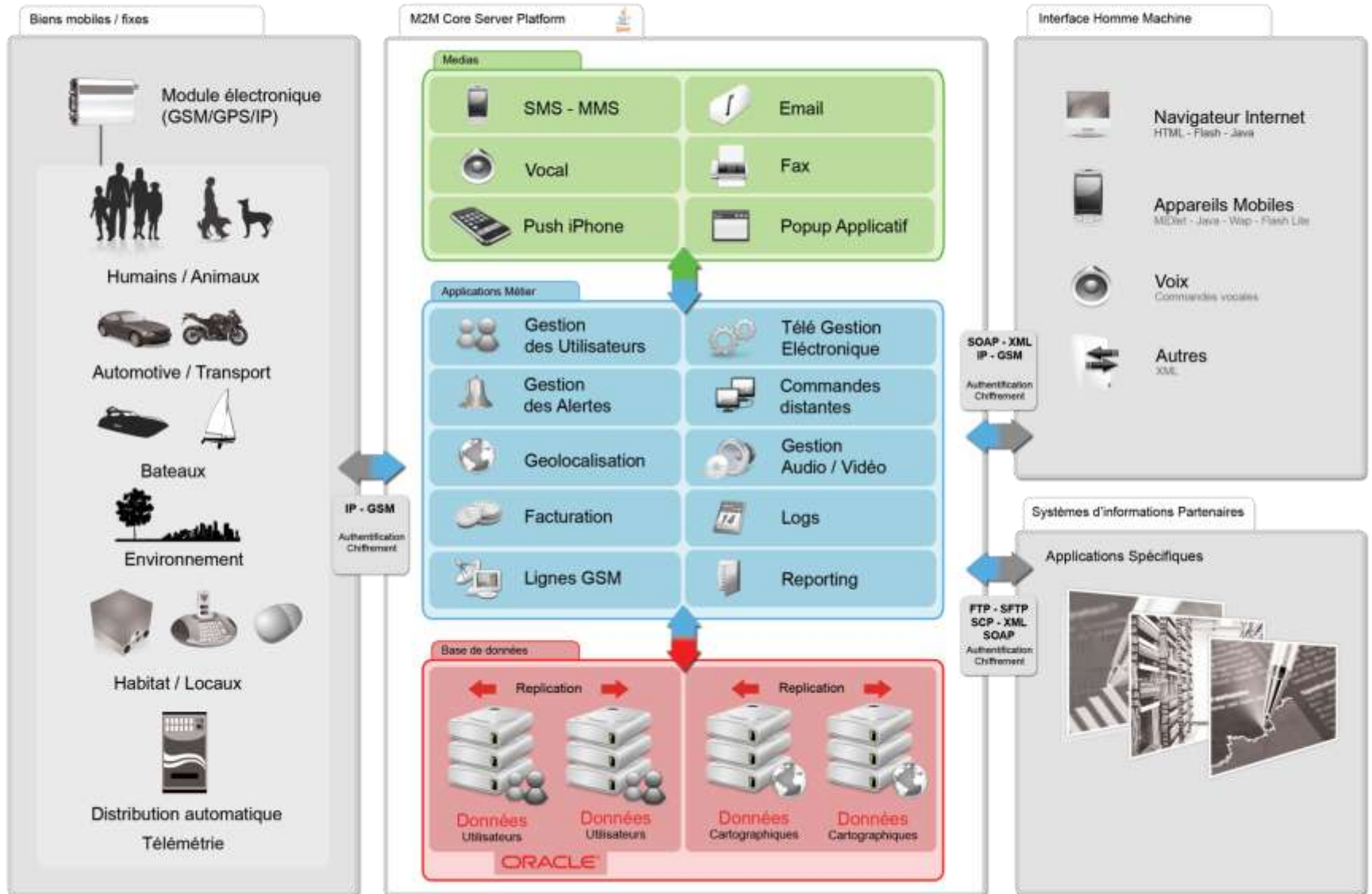

Design house for Multi-application electronic cards

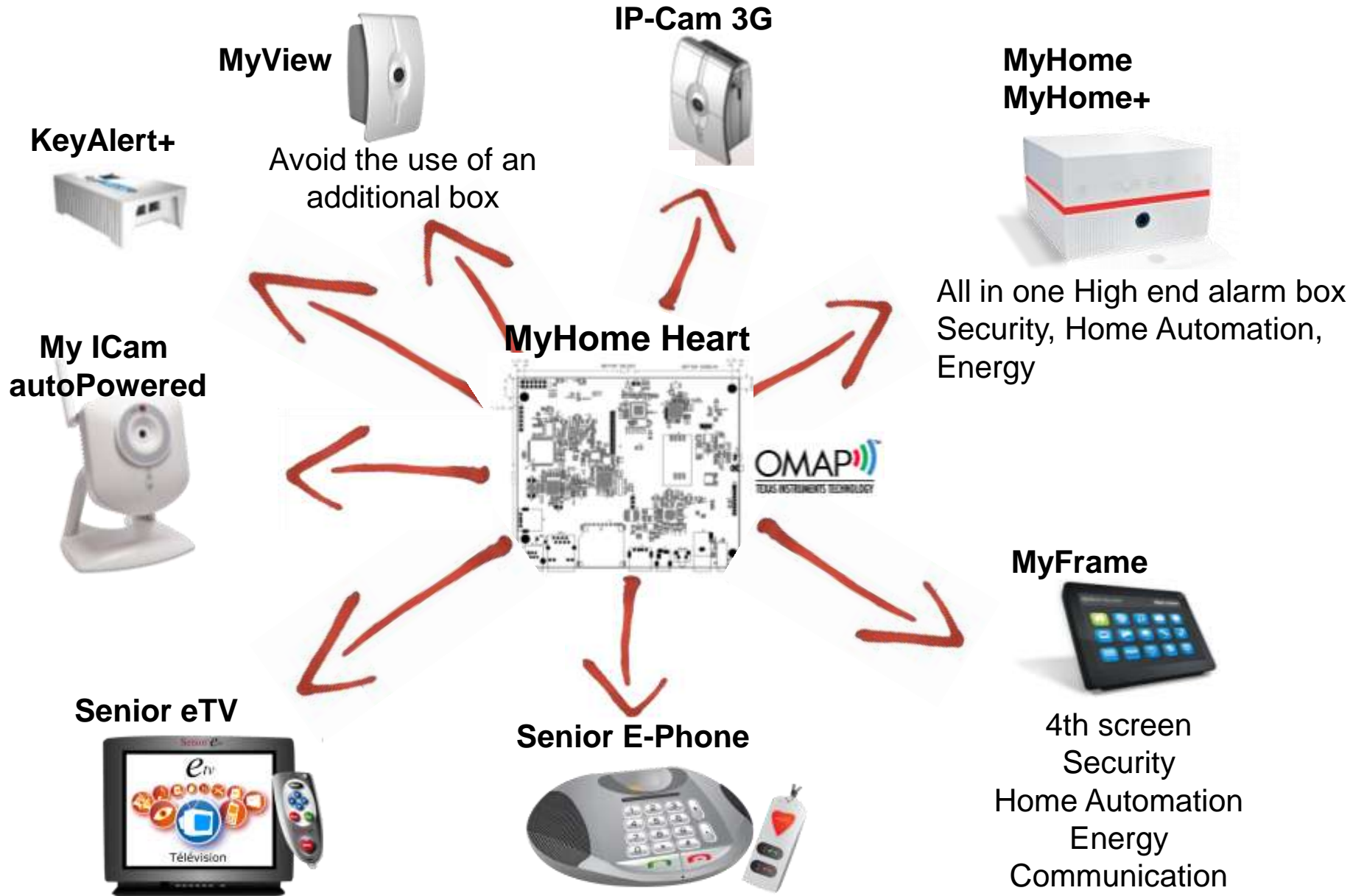

Powerful Partners

Powerful historical partnerships with leading suppliers provide massive deployment at reasonable cost



www.deltadore.fr/

Deltadore supplies white branded **sensors** as well as it's **X2D** protocol for Myhome & Myalert products. Deltadore is specialized in the supply of electronic sensors for **security** and **home automation**. (over **6M** sensors in use)



www.teleatlas.com/

Historical partner who helped refine the 1st system designed by M2M Solution Teleatlas supplies street by street **cartographic** data around the world at **unequaled prices**



www.ti.com/

Thanks to their **OMAP** core, the R&D teams have perfected a very **robust** and **inexpensive** platform for use in product design. TI also offers very high **visibility** for shows



www.sfr.fr/

The signature of an exclusive contract with this operator allows M2M Solution to supply its clients with an inexpensive **Machine to Machine** **dedicated Sim card**.



www.asteel.fr/

m2m has chosen the Asteel group as **industrial** partner for the **Manufacture** of its products. Asteel has the capability of financing its Working Capital in case of significant market



www.benomad.com/

Essential complement to Teleatlas, the Benomad technological motor give visual interpretation over the Internet of **cartographic data**,



www.ogone.com/

Leader in **Secure Payment** over the Internet Ogone allows billing and direct debiting from any type of card in over 25 countries (**30 million** electronic transactions each year)



www.netsize.com/

Netsize connects to over **100** telecom operators around the world guaranteeing **sms** alert interoperability from the m2m Solution platform to client **telephones**

An operational service platform

The platform was funded by our B2B clients



Honeywell is the **European leader** in **domestic burglar alarm** systems (670.000 alarms sold annually). M2M Solution has designed and operates an Internet platform that allows alert reception and management by end users.

Advantages : First client with permission to launch M2M, remote surveillance security protocols, expertise in security market



Virbac is the premier veterinary **laboratory world-wide**. M2M Solution has designed and operates a platform that allows geolocalization of dogs.

Advantages: platform upgrade, client follow up, client billing, Interconnections



Technological subsidiary of the **Aéroports de Paris**. Suppliers of the entirety of the **technological building blocks** allowing the launch of their **fleet management** product.

Advantages : Sole integrater, montée en charge, SIM Card activation



M2M Solution is a **MachineToMachine partner** bringing SFR technological building blocks compatible with their SIM cards

Status: Test Pilot in follow up stage before potential deployment.

The i-Domotics market

Security

Energy

Multimedia

Automatism

Health

Based on a market study from 'basic', What are the 7 primary services needed by people ?

- ▶ Auto-surveillance of the house
- ▶ Technical Auto-surveillance
- ▶ Management of the Urgencies
- ▶ Energy saving mode
- ▶ Optimisation of energy at Home
- ▶ Alert on Water consumption
- ▶ Alert on Energy consumption

65% of people wants to have a fully integrated solution :

- ▶ Security,
- ▶ Home Automation,
- ▶ Energy Management

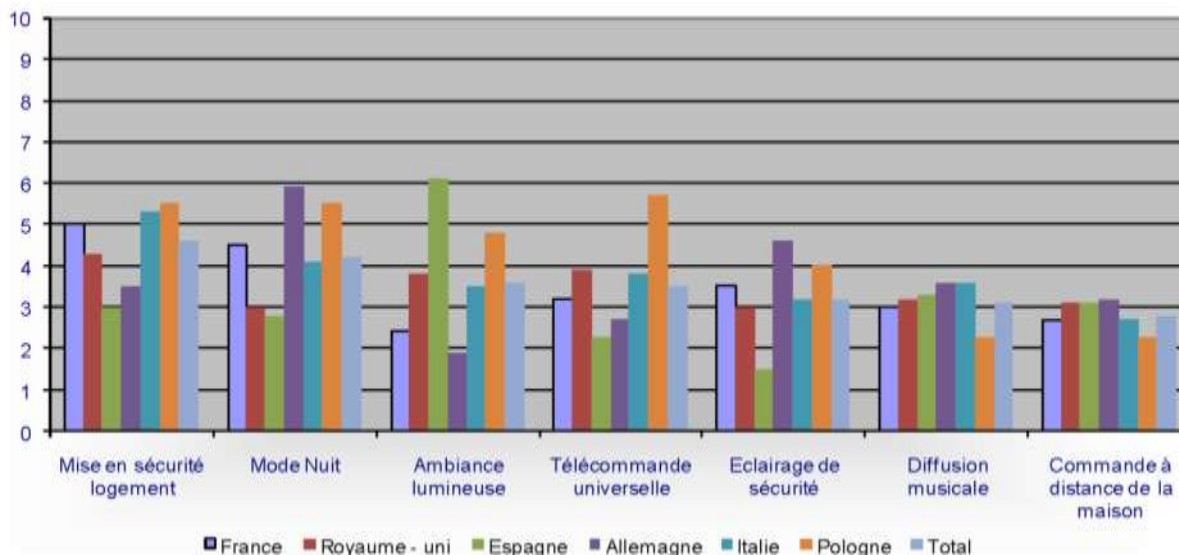

And the secondary services



Security : a primary necessity

- ▶ **312.000** break-ins / **143.000** car thefts in France in 2007
40% greater Parisian residents have been victimized

- ▶ Security is a **primary necessity** :

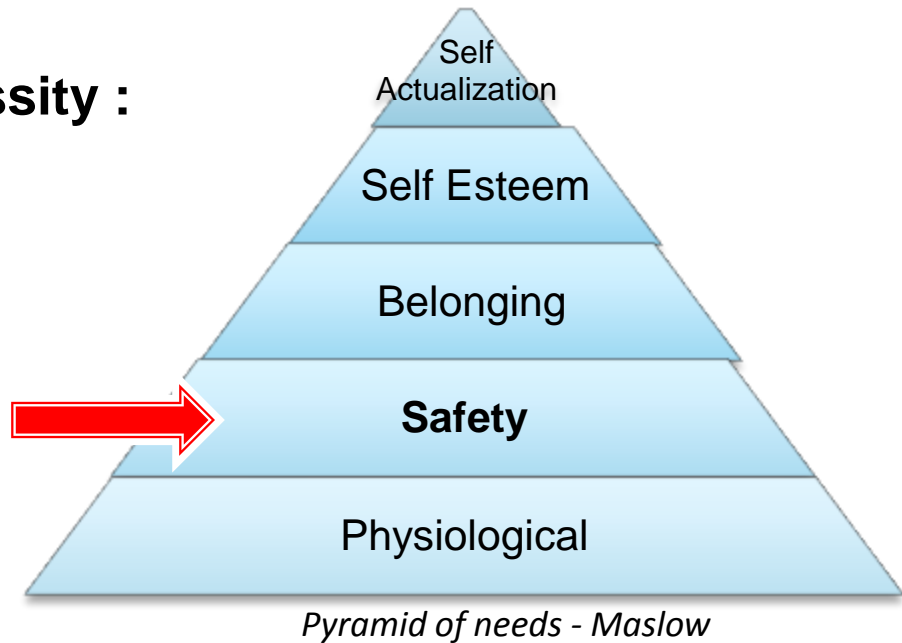

- ▶ Theft is experienced as moral trauma:
Theft of sentimental objects and invasion of personal space

Security : a fast-growing non-cyclical market

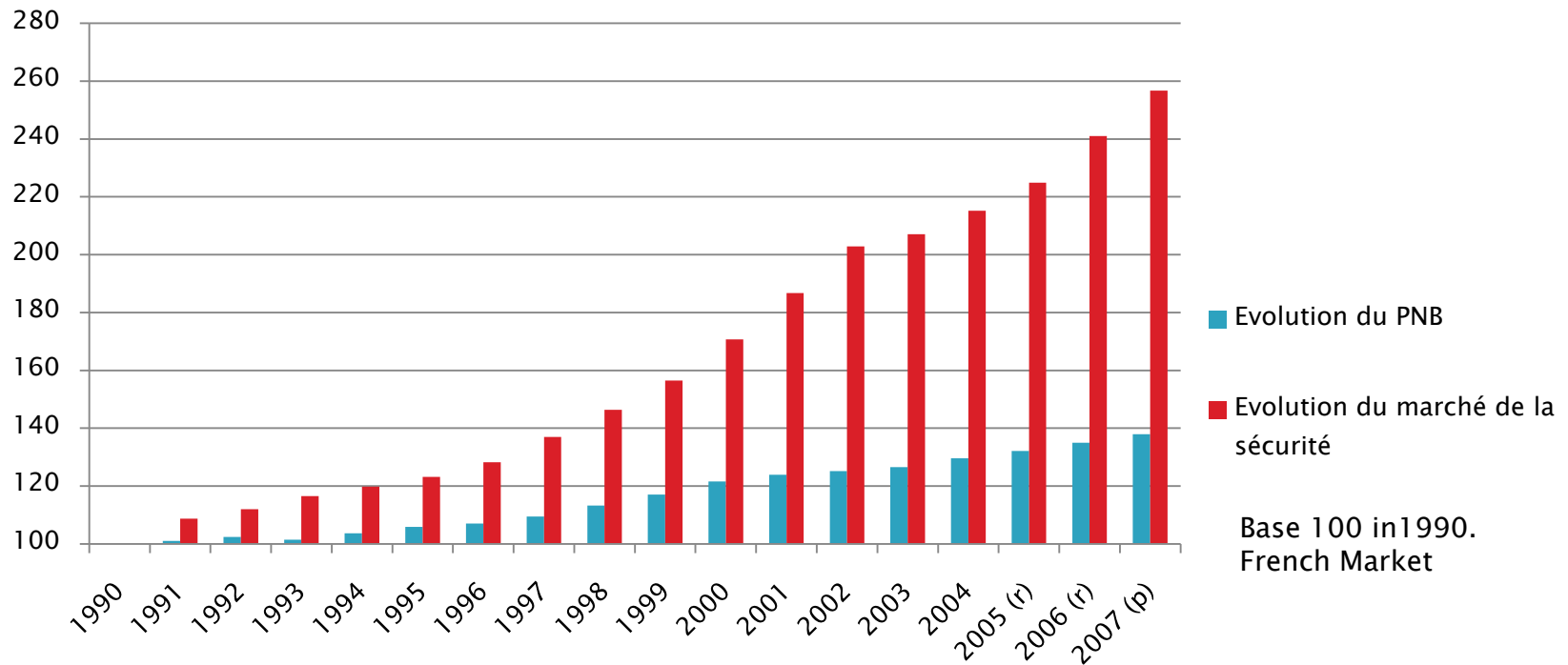

- ▶ French market in 2006: +18 billion €
- ▶ Strong growth even in times of crisis:
Actual example: explosion in sales of safes (+35% in 1 month)
- ▶ Successful sales of AT & T in the USA in security low cost (> 2 millions subscribers)

The European market is poorly supplied

Market segments	In Million units	competition			Focus M2M Solution
		No of players	Efficiency	Price	
Home	222	Many	Fairly good	Very expensive	++++
car	242	Few	Good	Expensive	+++
cycle	19	Very few	Poor	Expensive	+++
boat	3	Infancy	Poor	Very expensive	+
pets	46	Infancy	-	-	+
kids	32	Infancy	-	-	++
Senior	84	Infancy	-	-	++

Source: Company estimations

The Home Market Offering

3

Main ways of Distribution

	Home Made Shops	Specialized Street Networks	Telesurveillance
Content of the Offers	<p>Base Package:</p> <ul style="list-style-type: none"> 1 siren with integrated Alarm (4 areas) 2 Motion detectors 1 intrusion sensor 1 remote control 1 keyboard, 1 RTC transmission modem <p>No associated services</p>	<p>Base Package:</p> <ul style="list-style-type: none"> 1 siren with integrated Alarm (4 areas) 2 Motion detectors 1 intrusion sensor 1 remote control 1 keyboard, 1 RTC transmission modem <p>No associated services</p>	<p>Base Package:</p> <ul style="list-style-type: none"> 1 siren with integrated Alarm (4 areas) 2 Motion detectors 1 intrusion sensor 1 remote control 1 keyboard, - Télésurveillance - Hotline - System Maintenance
Price	Price : 600 to 1700 Euros	Price : 1200 à 3800 Euros Standard Set-up	Price: 399 Euros TTC Installation : 99 – 149 Euros Service : 25-30 Euros per month (over 36 month)
Options	<p>Add. sensor : from 39 to 199 €</p> <p>Camera : From 300 to 750 €</p>	<p>Add. sensor : from 135 to 425 €</p> <p>Camera : From 500 to 1200 €</p>	<p>Intervention on site + 15€/month</p> <p>Camera : 12 to 20 €/month</p>

Our answer

Becomes actor of your owns

- ▶ You will :

- be alerted via WAP, e-mails, SMS and voice calls.
- manage alerts via **visualization**, voice calls, **geolocalization**
- call the police

- ▶ A very attractive price: 3 or 4 times less than the actual security offer

- ▶ **Simple asset** security management of all your assets and family members via telephone or Internet

MY home.
MY car.
MY bike.
MY boat.



MY dog.
MY kids.
MY senior.
MY...

A very simple user Interface



virtualarme
@POWERED BY M2MSOLUTION

Logged user: client128



ACTIONS

ALERTS

SETUP

HISTORY

PROFILE

INFO

Protection mode

Protection Disarmed | Partial Protection Armed | Protection Armed

Warning signals (when Protection Disarmed)

Name	Type	Actions	Status
Sirène Intégrée	Built-in Siren	OFF	Arm Disarmed
Sirène1	Siren	OFF	Arm Disarmed

My sensors (when Protection Disarmed)

Name	Type	Actions	Status
Webcam	Built-in Camera (motion)	Arm	Disarmed
Détecteur humidité		Actif	Désactiver
Clavier RFID1		Actif	Désactiver
Badge	Remote control	Actif	Désactiver

Default settings | Pairing an accessory

VirtuAlarme Architecture

VirtuAlarme Production Stage

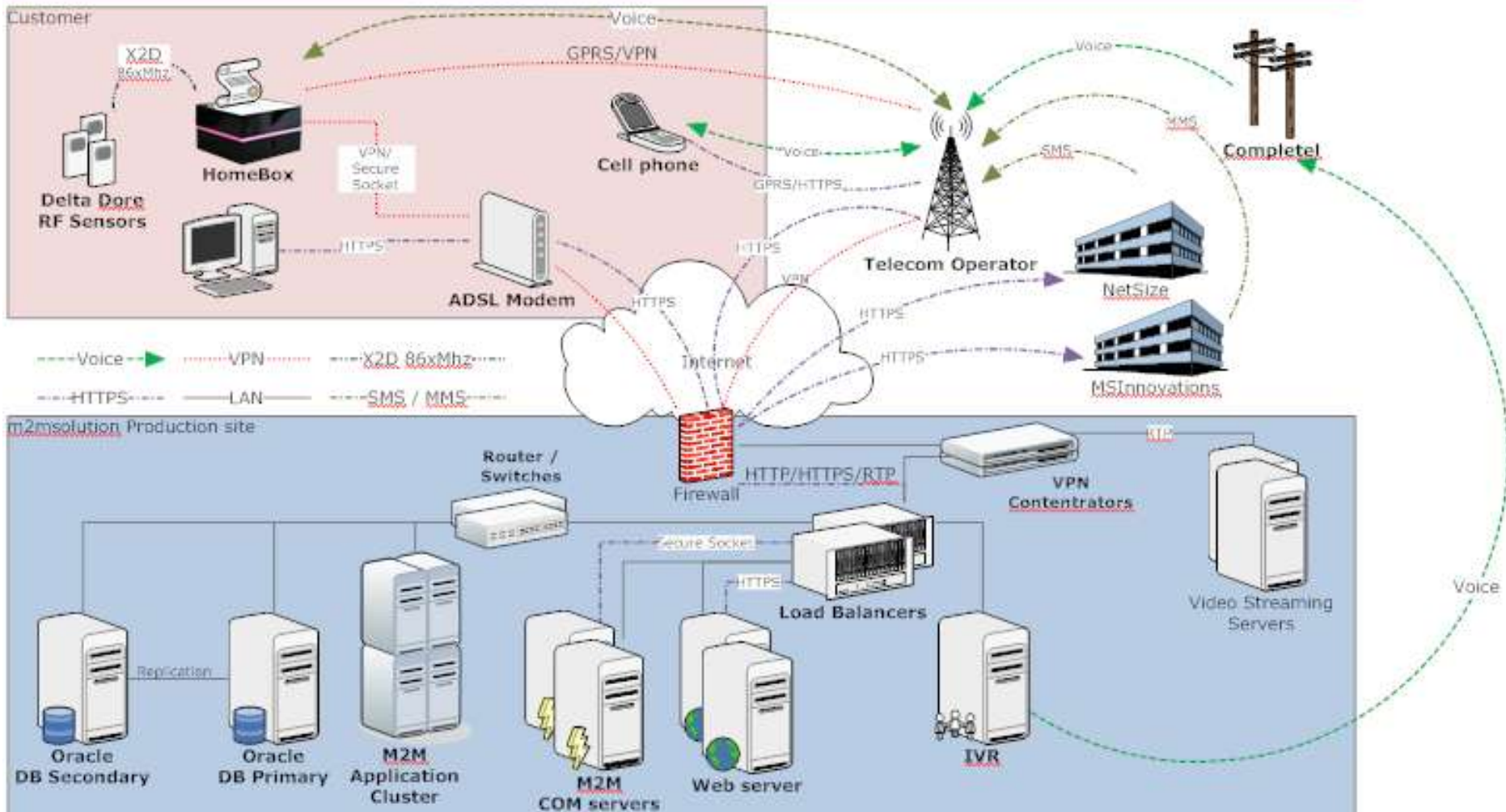

Other projects based on the homebox platform

Health Offer: Senior etv

- ▶ Security
- ▶ Comfort
- ▶ Phone
- ▶ Internet (simplified)
- ▶ Television
- ▶ Music
- ▶ Pay-per-view ?
- ▶ Dedicated Ad's (dedicated agency)
- ▶ A Dedicated TV Channel ?

On-Line Demo



Health Offer: Senior e-phone

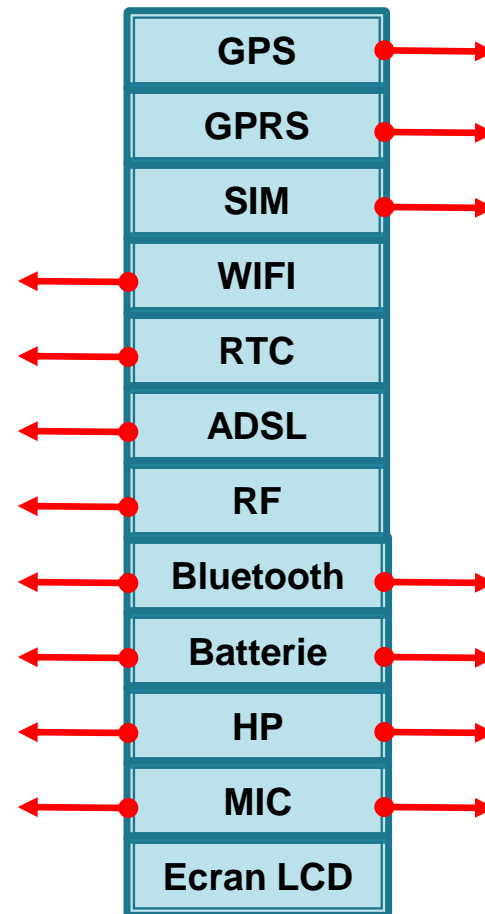

i-Domotic & multimedia Tablet

On-Line Demo



PHASE 1

- Security homebox (VirtuAlarm)
- Home Metering & Control
- Device Management
- Connected Widgets
- Entertainment / Multimedia
- Communications
- DECT Phone integration



PHASE 2

The strategy

BtoB or BtoC

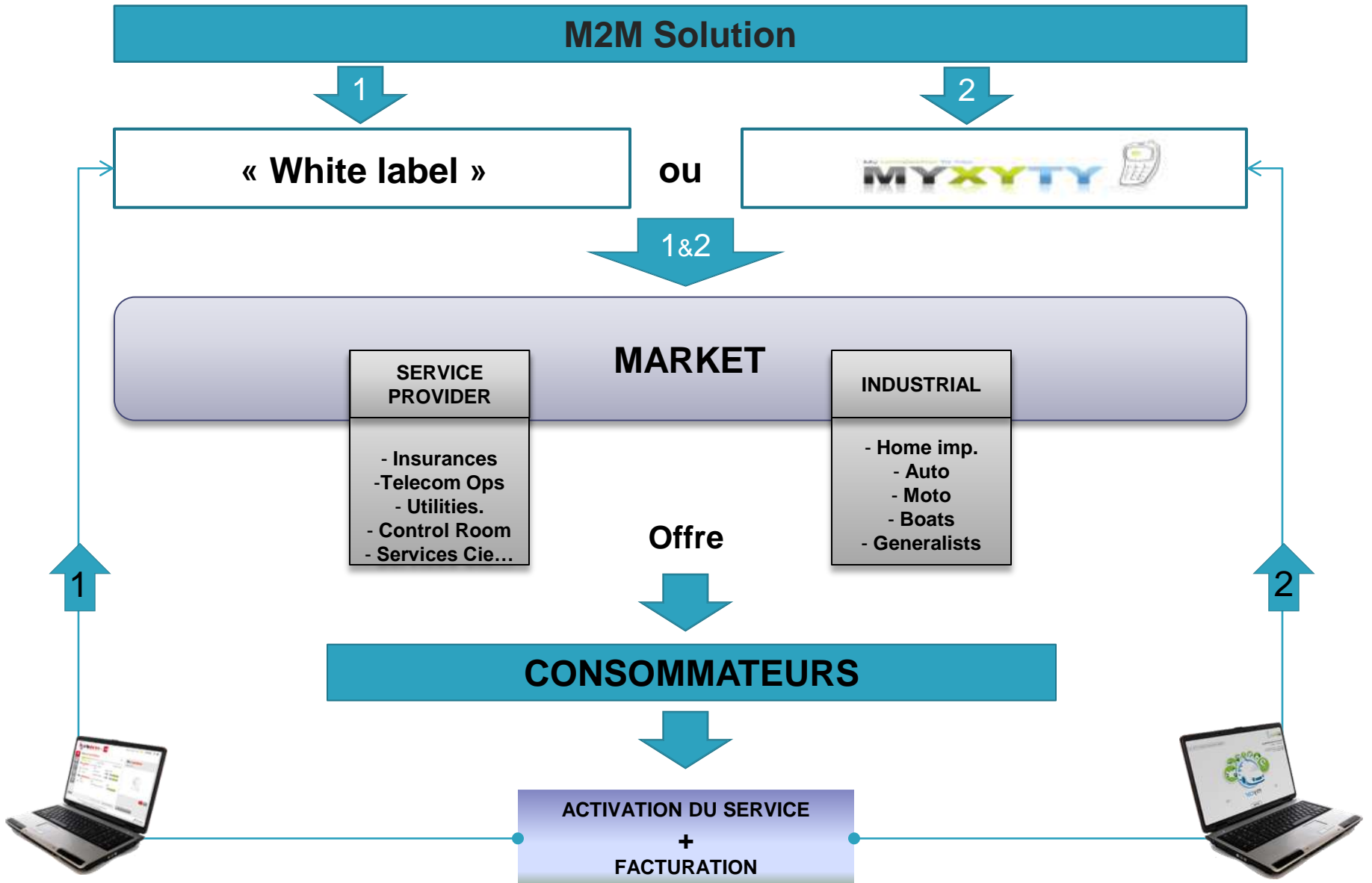

International simplified deployment

- ▶ Internationalisation relying on European partners and local partners
- ▶ The platform was designed to be easily deployable abroad
- ▶ Universal technologies (GSM, GPS, Internet & SIM)
- ▶ Multilingual portal
- ▶ Capability to invoice in any country (Ogone)
- ▶ Model rapidly replicated

